

NEEDLE & EXHAUST VALVES

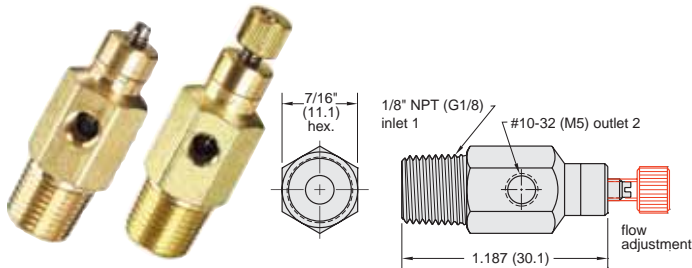

3° Needle Valves, 1/8" NPT



Input Pressure: 2000 psig/40 bar max.

Air Flow: 2.5 SCFM @ 50 psig; 5 SCFM @ 100 psig; 120 l/min @ 6 bar

Part No.	Description
MNV-3P	Needle Valve, #10-32, Screwdriver Slot
MNV-3P-M5	Needle Valve, M5, Screwdriver Slot
MNV-3KP	Needle Valve, #10-32, Knurled Knob
MNV-3KP-M5	Needle Valve, M5, Knurled Knob

3° Needle Valves, #10-32

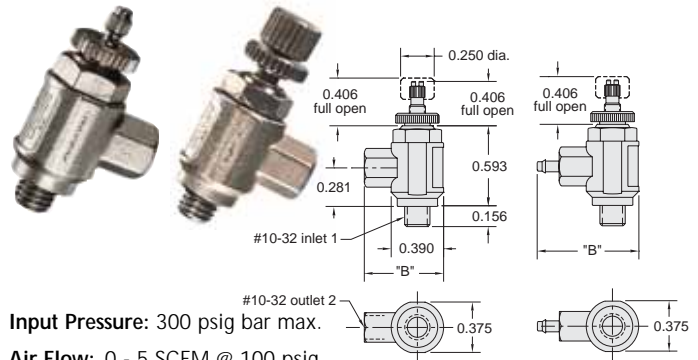

Input Pressure: 300 psig bar max.

Air Flow: 0 - 5 SCFM @ 100 psig

Part No.	Female Part	"B"	Adjustment
MNV-4	#10-32	.0593	Knurled locking nut standard; screwdriver slot; knurled locking nut standard; clockwise adjustment of either provides less flow
MNV-41	.1/16 Barb	.0750	Knurled knob; clockwise adjustment of either provides less flow
MNV-42	.1/8 Barb	.0906	
MNV-4K	#10-32	.0593	Knurled knob; clockwise adjustment of either provides less flow
MNV-4K1	.1/16 Barb	.0750	
MNV-4K2	.1/8 Barb	.0906	

QUICK EXHAUST VALVE APPLICATION

In a typical application the exhaust valve is installed in the inlet of a spring return or double acting pneumatic cylinder.

Supply air from a control valve is directed into the inlet port of the exhaust valve. The Buna-N poppet seals the exhaust port and allows air to flow from the outlet port of the valve into the cylinder.

The pressurized air pushes against the piston and extends the rod, compressing the spring, until full rod extension is achieved.

When the control valve exhausts air from the exhaust valve inlet port, the Buna-N poppet shifts to seal the inlet port and open the exhaust port to the cylinder. The pressurized air is allowed to exhaust directly through the exhaust valve to atmosphere.

Normally the air must travel back through the long air line to the control valve to exhaust. By mounting the exhaust valve directly on the cylinder, the piston retracts quickly since the distance to atmosphere is very short and unrestricted.

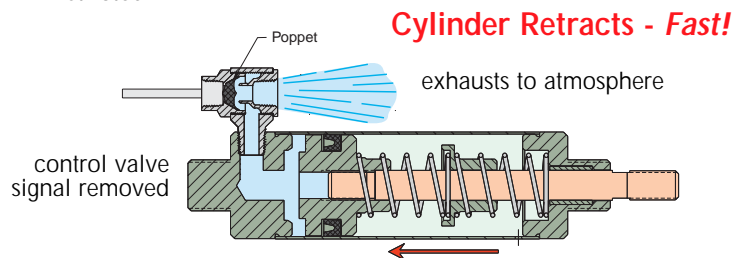
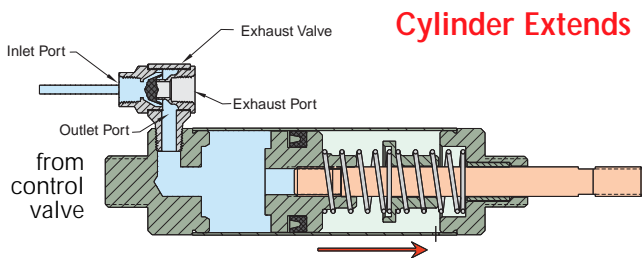

Poppet Quick Exhaust Valve

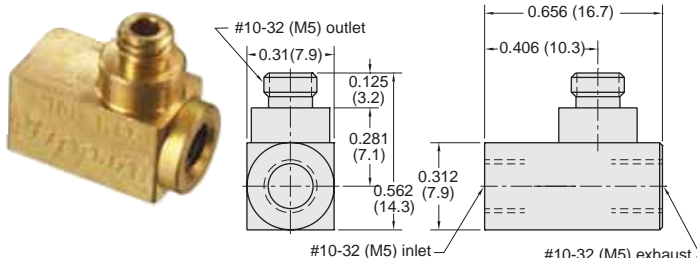

Part No.	Description
MEV-2	Poppet Type Quick Exhaust Valve, #10-32
MEV-2-M5	Poppet Type Quick Exhaust Valve, M5

Medium: Air

Material: Brass body, Buna-N poppet

Working Range: 15-150 psig/35-10 bar max.

Air Flow: 5 SCFM @ 50 psig; 9 SCFM @ 100 psig (exhaust rate); 220 l/min @ 6 bar

Mounting: Direct to cylinder

Pressure to Shift: @ 50 psig - opens after approx. 5 psig drop; @ 3.5 bar - opens after approx. 0.350 bar drop

Note: Not for use with cylinders larger than 7/8" dia.; moderate strokes up to 10"